

BEST PAIR III

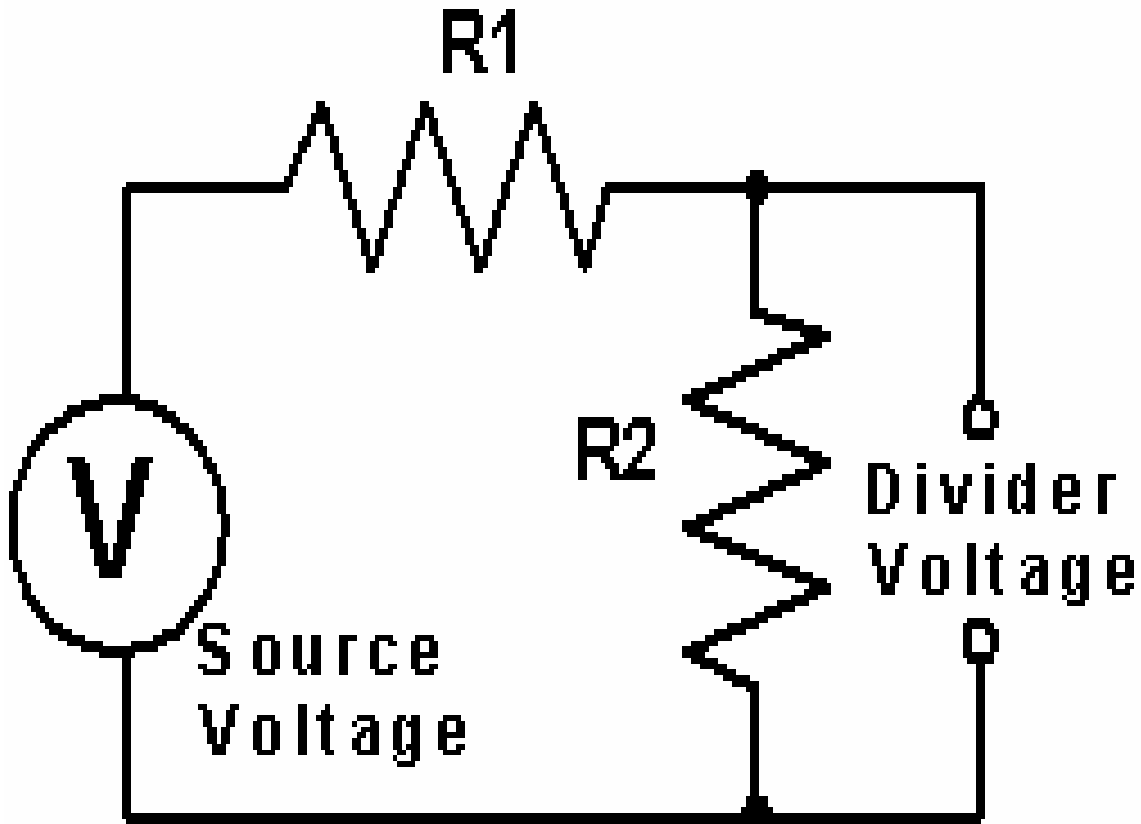

OPERATION

The diagram above defines the field names on the Best Pair entry form.

- Enter the source and divider voltages in the Best Pair form. These are required entries.
- Click on the CALC button to display the best pairs..

Results are calculated for 1% (E96), 5% (E24) and 0.1% (E192) resistor value sets. Click on the tabs above the results table to reveal results for each resistor value set.

The very best pair is displayed as the first item in the table. Twenty other resistor pairs will be displayed after the very best pair. These twenty pairs are selected to include the best pairs **AROUND** the very best pair. That is - they are selected to include pairs with positive and negative error results. In some cases they are not the twenty very best pairs. They are however the ten very best pairs with positive errors and the ten very best pairs with negative errors.

Also displayed are the error voltages, percent error, 'Perfect R2' and 'R Thevenin' values for each pair.

The 'Perfect R2' column is the exact R2 resistance value required to develop the desired divider voltage.

The 'R Thevenin' column is the Thevenin equivalent value, or output resistance, for the resistor network.

You can scale the resistor values to set the desired network current or Thevenin equivalent value. For example, if the Best Pair reports 909 ohms and 287 ohms, you can scale the values by 100 and use 90.9 K and 28.7 K ohms to reduce the network current and increase the Thevenin equivalent value by a factor of 100.

PRINTING

You can print the currently selected results table from the FILE/PRINT menu. The program sets the printer orientation to LANDSCAPE so that the result table will not be clipped on some printers.

UNINSTALL

Use Windows' Add/Remove Programs to uninstall Best Pair. Add/Remove Programs can be found in the Control Panel.